

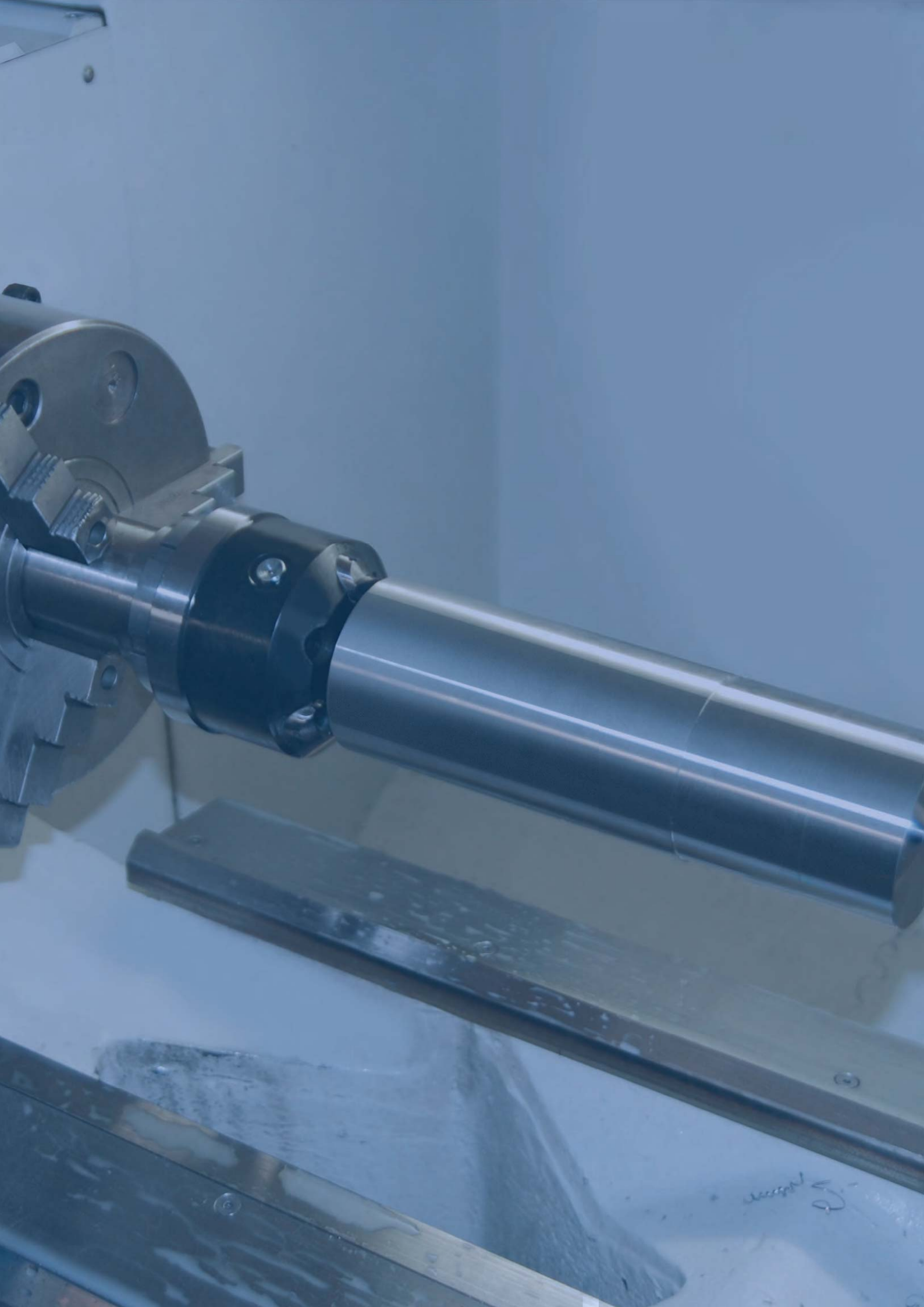

LIVE CENTRES FACE DRIVERS

EDITION 8

ROHM
driven by technology





TURNING AND MILLING IN ONE SET-UP

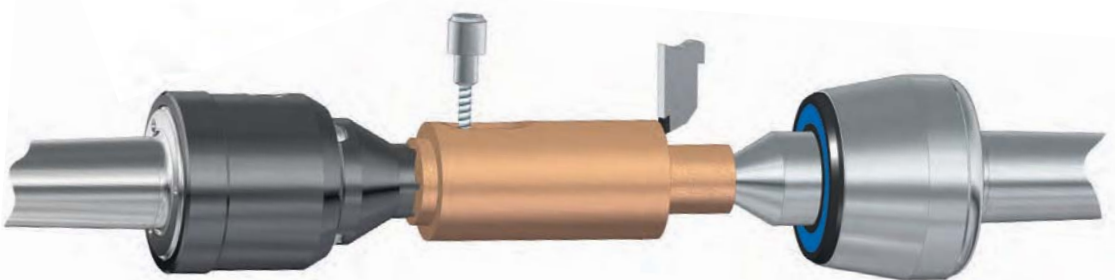

Application example face driver CoE in combination with a revolving live centre.
Turning and milling workpieces in one set-up.



Video CoE

CONSTANT FACE DRIVERS

The Constant face drivers of RÖHM are optimally suited for the rational turning and milling of workpieces over their entire length. All Constant face drivers are developed according to the modular principle, so that a universal exchange of a large multitude of driver discs and centre points is possible.

ADVANTAGES AT A GLANCE

- ⊕ Maximum flexibility thanks to the modular principle
- ⊕ High concentricity thanks to narrow tolerances
- ⊕ Constant clamping force thanks to mechanical or hydraulic pressure compensation, even for uneven workpiece faces

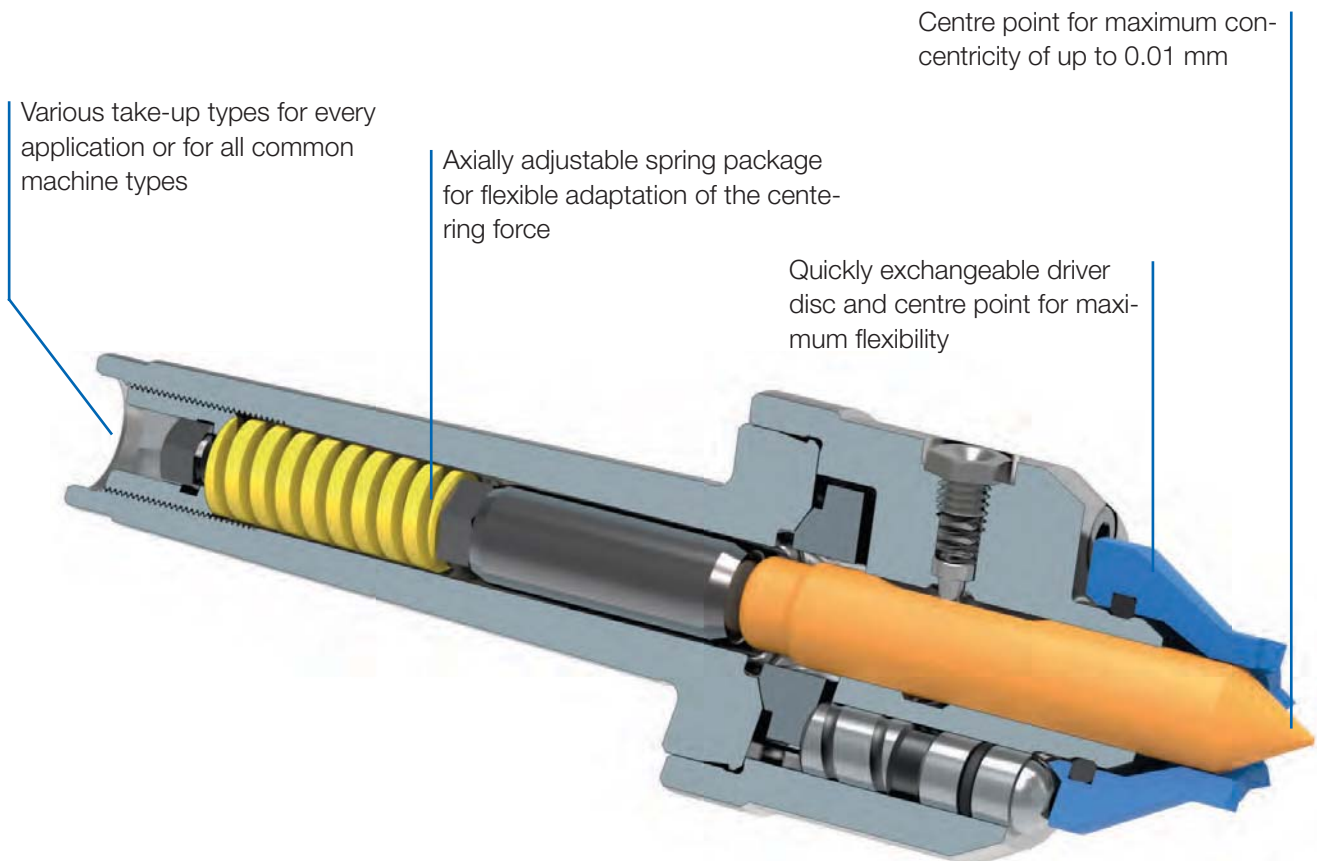

Operation guide



TYPE	CoE	CoA	CoK
Machining	Turning and milling in one set-up Patented compensating driving disc, radially backlash-free	Turning	Turning For machining workpieces which are highly unbalanced, very heavy, for high chip removal or for irregular cutting
Concentricity deviation max.	0.015 mm	0.015 mm	0.015 mm
Actuation	not power-operated	not power-operated	power-operated
Pressure compensation	mechanical	hydraulic / mechanical	mechanical
Workpiece weight	up to 100 kg	up to 100 kg	up to 350 kg
Centre point	resilient	resilient	fixed
Clamping-Ø	8 - 80 mm	8 - 80 mm	8 - 80 mm
Adapter	with morse taper / with cylindrical shank	with morse taper / with morse taper and draw-off nut / with cylindrical shank for clamping in lathe chucks / with short taper / in flange type	with centring mount for adapter plate
Page	2040	2043	2052

TYPE	CoM	CoB
Machining	Turning For clamping large and heavy workpieces, as well as workpieces with extremely uneven faces	Turning For clamping large and heavy workpieces, as well as workpieces with extremely uneven faces
Concentricity deviation max.	0.015 mm	0.015 mm
Actuation	not power-operated	not power-operated
Pressure compensation	mechanical	hydraulic
Workpiece weight	up to 500 kg	up to 500 kg / 1.000 kg
Centre point	resilient, axially adjustable	resilient, axially adjustable
Clamping-Ø	50 - 250 mm	63 - 160 mm
Adapter	with morse taper / with short taper	with morse taper / with short taper
Page	2055	2055

Clamping power diagramm

Clamping power diagramm

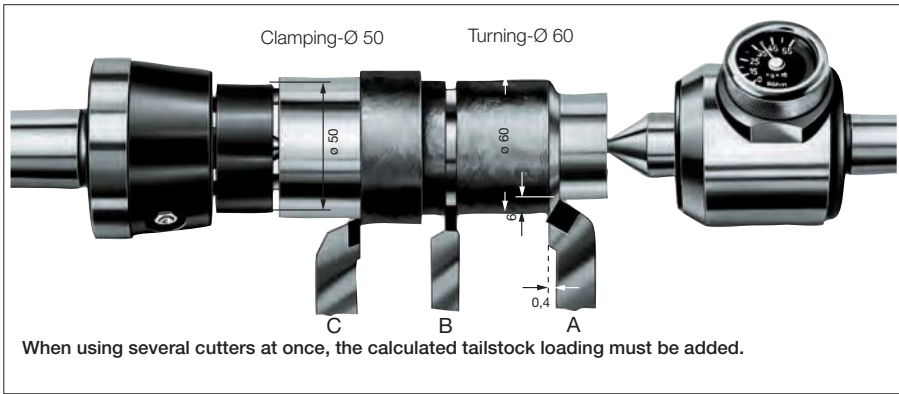

- Example**
- A** Turning against the headstock
 - 1. Cutting capacity: $6 \times 0,4 = 2,4 \text{ mm}^2$
 - 2. Workpiece strength: $= 63 \text{ daN/mm}^2$
 - 3. Clamping ratio: $60 : 50 = 1,2$
 - 4. Tailstock loading from graph: $F_{\text{Tailstock}} = 450 \text{ daN}$
 - * Conversation factor for:
 - B** Radial grooving $F_{\text{Tailstock}} \times 1,5$
 - C** Turning against tailstock $F_{\text{Tailstock}} \times 2$

Workpiece strength daN/mm ²	40	50	63	80	100	125
Material	St 34-37	St 42	St 50	St 60-70	20 MnCr 5	18CrNi 8
	9-15 S 20	C 10	C 15-22	C 35-45	C 60	30 CrMoV 9
	GG 14-35	GG 40	22 S 20	16 MnCr 5	15 CrNi 6	50 CrMo 4
	GGG-38	GGG-42	GGG-50	GGG-60	GGG-80	105 WCr 6

The RÖHM slide rule, Item No. 88230 may also be used for easy calculation of the axial clamping power.

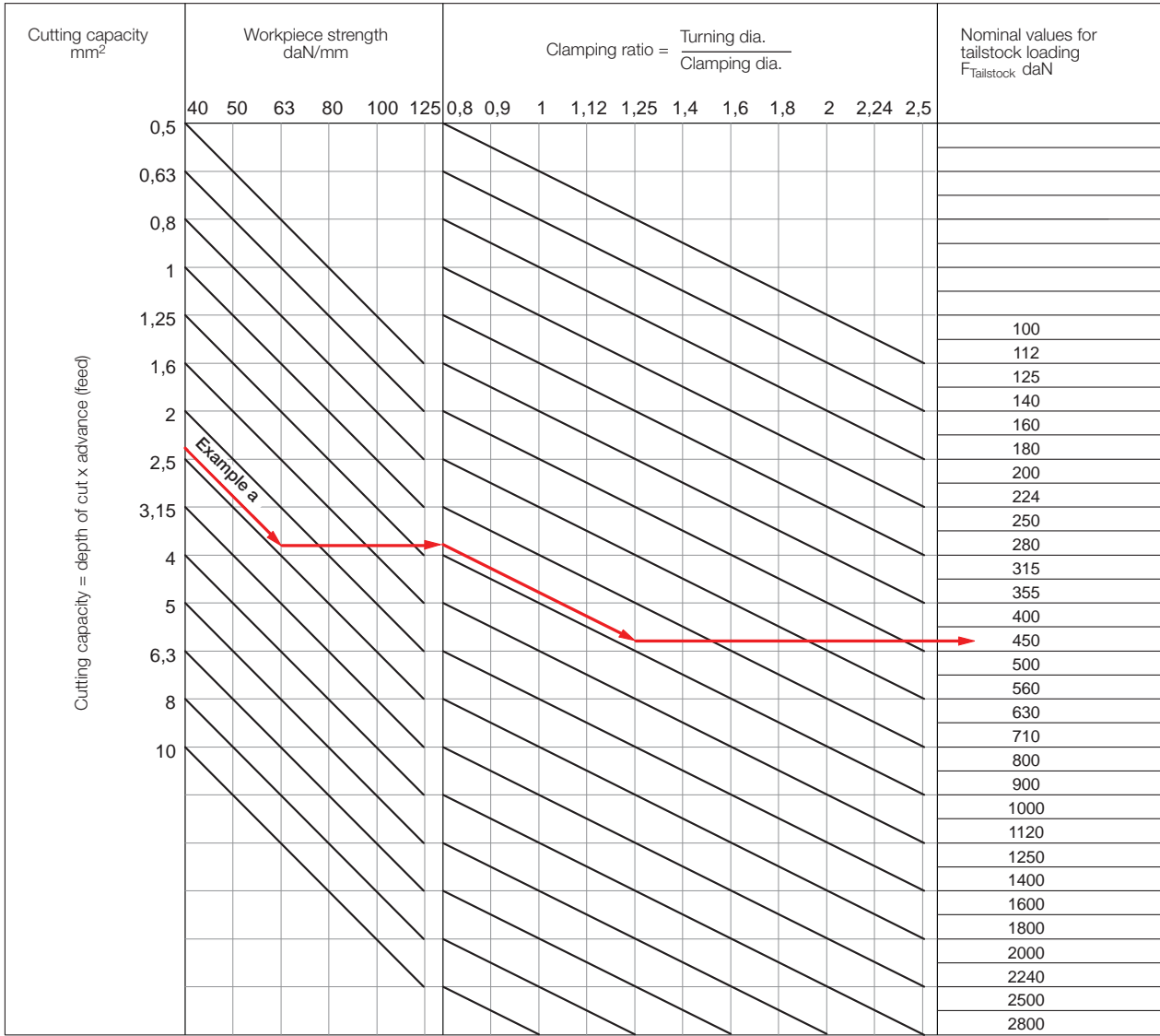

CoE - turning and milling

Constant face drivers
CoE

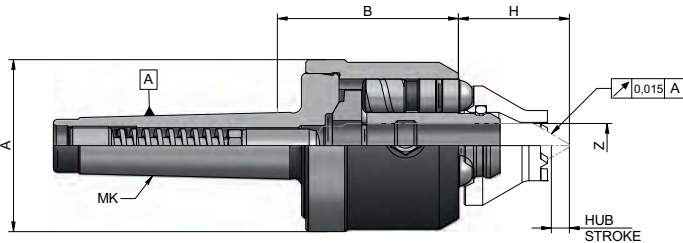

APPLICATION

For the rational **turning and milling** of workpieces on its entire length without reclamping with maximum precision.

TYPE

Basic body with morse taper and mechanical pressure compensation.
Clamping circuit Ø 8-80 mm.
Workpiece weight max. 100 kg.

CUSTOMER BENEFITS

- ⊕ For **turning and milling** in one set-up
- ⊕ Compensating driving disc, radially backlash-free
- ⊕ Maximum concentricity deviation of 0.015 mm for maximum precision
- ⊕ Stable and constant workpiece length stop on the front side thanks to resilient centre point
- ⊕ Maximum flexibility thanks to universal exchange of driving disc and centre point

TECHNICAL FEATURES

- Guide value for axially permissible total load on 3 support pistons: 9000 N

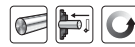

A14

Basic body with morse taper (all basic bodies without driving disc and centre), **mechanical**

Item no.	MT	A mm	B mm	H mm	Z mm	Centres stroke mm	Weight approx. g
310065	3	62	65	max. 38 min. 26	16	10	1800
310066	4	62	65	max. 38 min. 26	16	10	1900
310068	5	62	65	max. 38 min. 26	16	10	2000

Other take-ups available on request

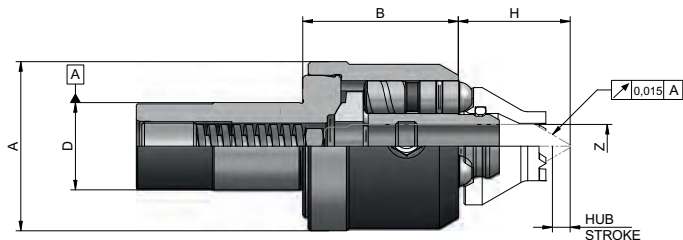

APPLICATION

For the rational **turning and milling** of workpieces on its entire length without reclamping with maximum precision.

TYPE

Basic body with cylinder shaft and mechanical pressure compensation.
Clamping circuit Ø 8-80 mm.
Workpiece weight max. 100 kg.

CUSTOMER BENEFITS

- ⊕ For **turning and milling** in one set-up
- ⊕ Compensating driving disc, radially backlash-free
- ⊕ Maximum concentricity deviation of 0.015 mm for maximum precision
- ⊕ Stable and constant workpiece length stop on the front side thanks to resilient centre point
- ⊕ Maximum flexibility thanks to universal exchange of driving disc and centre point

TECHNICAL FEATURES

- Guide value for axially permissible total load on 3 support pistons: 9000 N

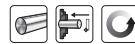

A14

Basic body with cylindrical shank (all basic bodies without driving disc and centre), **mechanical**

Item no.	Center Ø mm	A mm	B mm	H mm	Z mm	Centres stroke mm	Weight approx. g
310071	25	62	56	max.38 min.26	16	10	1900
310072	32	62	56	max.38 min.27	16	10	2000

Other take-ups available on request

Accessories CoE

A14

Driving discs, toothed, right- and left-hand rotation, free from play, max. workpiece hardness 35 HRC

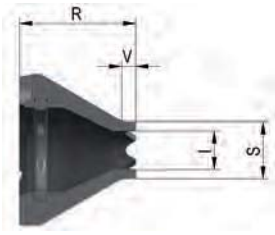

Item no.	Clamping circuit Ø S mm	Approx. turning range	l mm	R mm	V mm	Assoc. centre point Ø Y mm	Axial load max. N
1209000	8	9-16	4,5	38	4	4	4000
1209001	10	11-20	4,5	38	4	4	6000
1209002	12	13-24	7	36	4	6	6000
1209003	16	17-32	11	33	4	10	6000
1209004	20	21-40	13	30	4	12	8000
1209005	25	26-50	17	30	8	16	9000
1209006	32	33-64	22	30	10	16	9000

Driving discs with carbide tothing on request

A14

Driving discs, with interchangeable carbide driving plates 6 x 3,2, right- and left-hand rotation, free from play, max. workpiece hardness 40 HRC

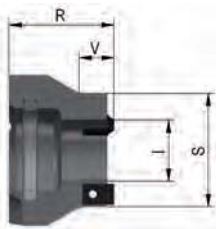

Item no.	Clamping circuit Ø S mm	Approx. turning range	l mm	R mm	V mm	Assoc. centre point Ø Y mm	Axial load max. N
1209007	20	21-40	7	30	8	6	9000
1209008	25	26-50	11	30	8	10	9000
1209009	32	33-64	17,5	30	10	16	9000
1209010	40	41-80	27	30	16	16	9000

A14

Driving discs, with interchangeable carbide driving plates 6 x 3,2, right- and left-hand rotation, free from play, max. workpiece hardness 40 HRC



Item no.	Clamping circuit Ø S mm	Approx. turning range	l mm	R mm	Assoc. centre point Ø Y mm	Axial load max. N
1209011	50	51-100	36	30	16	9000
1209012	63	64-126	49	30	16	9000
1209013	80	81-160	66	30	16	9000

A14

Centres

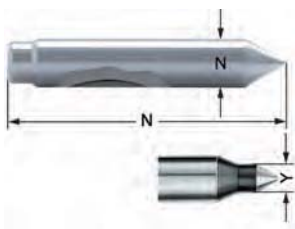

Item no.	Clamping circuit Ø S mm	N mm	Y mm	Z mm
1209016	8-10	90	4	16
1209017	12	90	6	16
1209018	16	90	10	16
1209019	20	90	12	16
1209020	25-80	90	16	16

Centering taper on request

A14

Carbide driving plates, right- and left-hand rotation



Item no.	Size	Clamping circuit Ø mm
088970	6x3,2	20-80

Accessories CoE

A14

Mounting sleeve for clamping the face driver in the lathe chuck

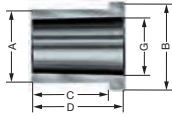

Item no.	MT inside	A mm	B mm	C mm	D mm	G mm
085033	3	32	39	32	40	23,825
085034	4	40	47	42	50	31,267
085035	5	55	62	52	60	44,399

Face driver accessories CoE

CoE - product ranges

A14

CoE small assortment in wooden box, mechanical pressure compensation, clamping circuit \varnothing 12-50 mm, turning range 13-100 mm

Included in delivery: 1x basic body, 4x driving discs (clamping circuit \varnothing 12, 20, 32, 50), 3x centre points (centering \varnothing 6, 12, 16)



Item no.	Mount	Weight approx. g
10004070	ZA 32	3600
1209048	MK 3	3600
1209049	MK 4	3870
1209050	MK 5	4550

CoA - turning

APPLICATION

For the rational turning of workpieces on its entire length without reclamping with maximum precision.

TYPE

Basic body with morse taper and hydraulic pressure compensation.
Clamping circuit Ø 8-80 mm.
Workpiece weight max. 100 kg.

CUSTOMER BENEFITS

- ⊕ Constant clamping force thanks to hydraulic pressure compensation, even for uneven workpiece faces
- ⊕ Stable and constant workpiece length stop on the front side thanks to resilient centre point
- ⊕ Maximum concentricity deviation of 0.015 mm for maximum precision
- ⊕ Maximum flexibility thanks to universal exchange of driving disc and centre point

TECHNICAL FEATURES

- Guide value for axially permissible total load on 3 support pistons: 20.000 N

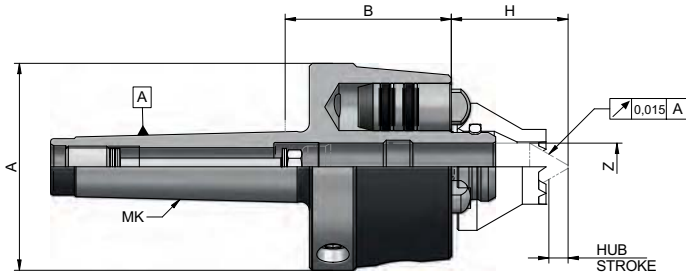
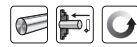

A14

Basic body with morse taper (basic body without driving disc and center), **hydraulic**

Item no.	MT	A mm	B mm	H mm	Z mm	Centres stroke mm	Weight approx. g
088173	3	70	54	max. 45 min. 26	16	10	1600
088174	4	70	56,5	max. 45 min. 26	16	15	1800
088175	5	70	56,5	max. 45 min. 26	16	15	2800
088176	6	70	56,5	max. 45 min. 26	16	15	4400

APPLICATION

For the rational turning of workpieces on its entire length without reclamping with maximum precision.

TYPE

Basic body with morse taper, draw-off nut and hydraulic pressure compensation.
Clamping circuit Ø 8-80 mm.
Workpiece weight max. 100 kg.

CUSTOMER BENEFITS

- ⊕ Constant clamping force thanks to hydraulic pressure compensation, even for uneven workpiece faces
- ⊕ Stable and constant workpiece length stop on the front side thanks to resilient centre point
- ⊕ Maximum concentricity deviation of 0.015 mm for maximum precision
- ⊕ Maximum flexibility thanks to universal exchange of driving disc and centre point

TECHNICAL FEATURES

- Guide value for axially permissible total load on 3 support pistons: 20.000 N

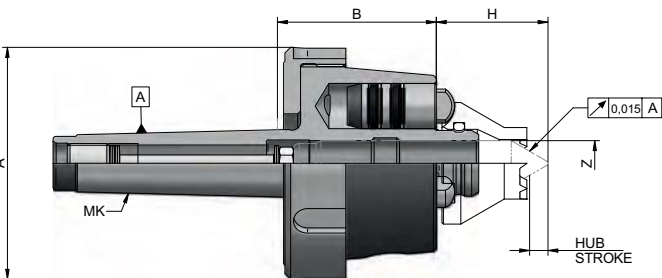
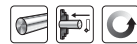

A14

Basic body with morse taper, with draw-off nut (basic body without driving disc and centre), **hydraulic**

Item no.	MT	A mm	B mm	H mm	Z mm	Centres stroke mm	Weight approx. g
088177	3	82	54	max. 45 min. 26	16	10	1800
088178	4	82	56,5	max. 45 min. 26	16	15	2200
088179	5	82	56,5	max. 45 min. 26	16	15	3000
088180	6	82	56,5	max. 45 min. 26	16	15	4600

CoA - turning

Constant face drivers
CoA

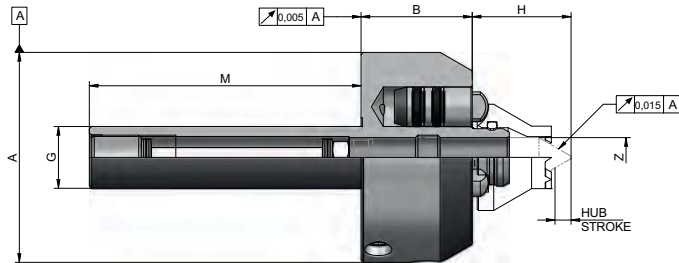

APPLICATION

For the rational turning of workpieces on its entire length without reclamping with maximum precision.

TYPE

Basic body with cylindrical shank and hydraulic pressure compensation.
Clamping circuit \varnothing 8-80 mm.
Workpiece weight max. 100 kg.

CUSTOMER BENEFITS

- ③ Constant clamping force thanks to hydraulic pressure compensation, even for uneven workpiece faces
- ③ Stable and constant workpiece length stop on the front side thanks to resilient centre point
- ③ Maximum concentricity deviation of 0.015 mm for maximum precision
- ③ Maximum flexibility thanks to universal exchange of driving disc and centre point

TECHNICAL FEATURES

- Guide value for axially permissible total load on 3 support pistons: 20.000 N

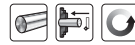

A14

Basic body with **cylindrical shank** for clamping in lathe chucks, with **spring package** (basic body without driving disc and centre), **mechanical / hydraulic**

Item no.	Clamping diameter A mm	B mm	G mm	H mm	M mm	Z mm	Centres stroke mm	Weight approx. g
088074 ¹⁾	85	45	25	max. 45 min. 26	110	16	15	2300
313085 ²⁾	85	45	25	max. 45 min. 26	110	16	15	2300

¹⁾ With hydraulic compensation

²⁾ With mechanical compensation

Dimension G is no clamping surface

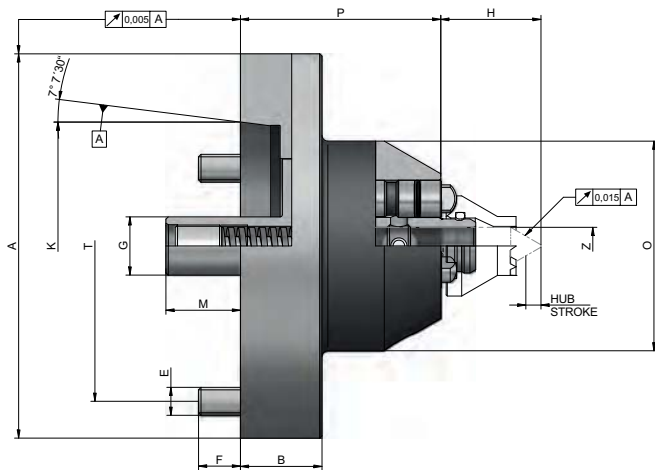

APPLICATION

For the rational turning of workpieces on its entire length without reclamping with maximum precision.

TYPE

Basic body with short taper and mechanical pressure compensation.
Clamping circuit \varnothing 8-80 mm.
Workpiece weight max. 100 kg.

CUSTOMER BENEFITS

- ③ Constant clamping force thanks to mechanical pressure compensation, even for uneven workpiece faces
- ③ Stable and constant workpiece length stop on the front side thanks to resilient centre point
- ③ Maximum concentricity deviation of 0.015 mm for maximum precision
- ③ Maximum flexibility thanks to universal exchange of driving disc and centre point

TECHNICAL FEATURES

- Guide value for axially permissible total load on 3 support pistons: 20.000 N

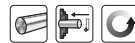

A14

Basic body with **short taper ISO 702-1** (DIN 55026), with **spring package** (basic body without driving disc and center), **mechanical**

Item no.	Short-taper	A mm	B mm	E	F mm	G mm	H mm	K mm	M mm	O mm	P mm	T mm	Z mm	Centres stroke mm	Weight approx. g
313905	5	133	-	M 10	15	25	max. 45 min. 26	82,563	32	90	86	104,8	16	10	6500
313906	6	165	35	M 12	18	25	max. 45 min. 26	106,375	32	90	86	133,4	16	10	7000
313907	8	210	40	M 16	23	25	max. 45 min. 26	139,719	32	90	86	171,4	16	10	8100

CoA - turning

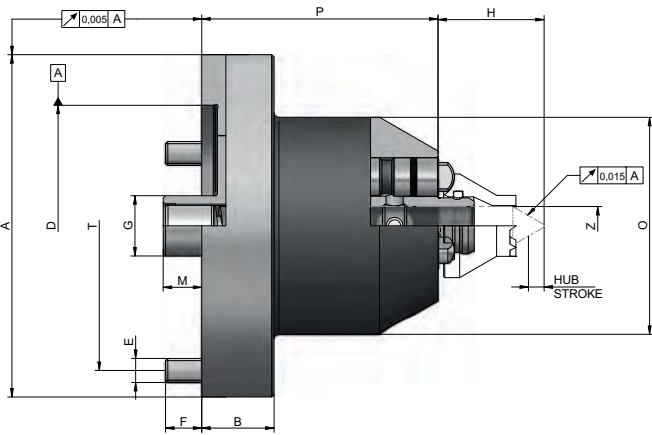

APPLICATION

For the rational turning of workpieces on its entire length without reclamping with maximum precision.

TYPE

Basic body with centring mount and hydraulic/mechanical pressure compensation.
Clamping circuit Ø 8-80 mm.
Workpiece weight max. 100 kg.

CUSTOMER BENEFITS

- ③ Constant clamping force thanks to hydraulic/mechanical pressure compensation, even for uneven workpiece faces
- ③ Stable and constant workpiece length stop on the front side thanks to resilient centre point
- ③ Maximum concentricity deviation of 0.015 mm for maximum precision
- ③ Maximum flexibility thanks to universal exchange of driving disc and centre point

TECHNICAL FEATURES

- Guide value for axially permissible total load on 3 support pistons: 20.000 N

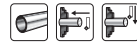

A14

Basic body flange type, with spring set (basic body without driving disc and center), **mechanical / hydraulic**

Item no.	A mm	B mm	D mm	E	F mm	G mm	H mm	M mm	O mm	P mm	T mm	Z mm	Centres stroke mm	Weight approx. g
088046 ¹⁾	142	30	100	M 10	15	25	max. 45 min. 26	61	90	98	120	16	15	7300
313910 ²⁾	142	30	100	M 10	15	25	max. 45 min. 26	16	90	98	120	16	10	7300

¹⁾ With hydraulic compensation

²⁾ With mechanical compensation

Adapter plate CoA

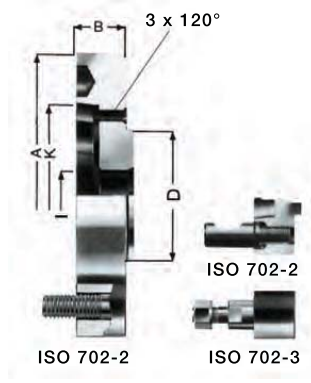

A14
Adapter plate **short taper**

Item no.	Design	Taper	A mm	B mm	D mm	I mm	K mm	Weight approx. g
088485	ISO 702-1	5	140	30	100	38	82,563	3100
088486	ISO 702-1	6	167	35	100	38	106,39	4800
088487	ISO 702-1	8	216	40	100	38	139,735	8700
088488	ISO 702-1	11	280	45	100	38	196,885	17000
088480	ISO 702-3	5	140	30	100	38	82,563	3100
088481	ISO 702-3	6	167	35	100	38	106,39	4800
088482	ISO 702-3	8	216	40	100	38	139,735	8700
088483	ISO 702-3	11	280	45	100	38	196,885	17000
088495	ISO 702-2	5	140	30	100	38	82,563	3100
088496	ISO 702-2	6	167	35	100	38	106,39	4800
088497	ISO 702-2	8	216	40	100	38	139,735	8700
088498	ISO 702-2	11	280	45	100	38	196,885	17000

Accessories CoA

A14

Driving discs, with interchangeable carbide driving plates 6 x 3.2, **right- and left-hand rotation**, max. workpiece hardness 40 HRC

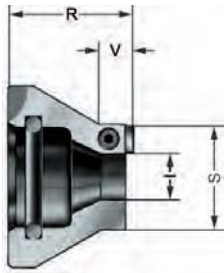

Item no.	Clamping circuit Ø S mm	Approx. turning range	l mm	R mm	V mm	Assoc. centre point Ø Y mm	Axial load max. N
088545	20 H	21-40	7	30	5	6	8000
088546	25 H	26-50	11	30	8	10	8000
088547	32 H	33-64	17,5	30	10	16	8000

A14

Driving discs, with interchangeable carbide driving plates 6 x 3.2, **right-hand rotation**, max. workpiece hardness 40 HRC

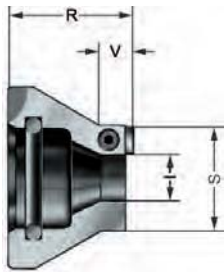

Item no.	Clamping circuit Ø S mm	Approx. turning range	l mm	R mm	V mm	Assoc. centre point Ø Y mm	Axial load max. N
089065	20 H	21-40	7	30	5	6	8000
089066	25 H	26-50	11	30	8	10	8000
089067	32 H	33-64	17,5	30	10	16	8000

A14

Driving discs, with interchangeable carbide driving plates 6 x 3.2, **left-hand rotation**, max. workpiece hardness 40 HRC

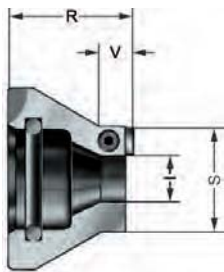

Item no.	Clamping circuit Ø S mm	Approx. turning range	l mm	R mm	V mm	Assoc. centre point Ø Y mm	Axial load max. N
089085	20 H	21-40	7	30	5	6	8000
089086	25 H	26-50	11	30	8	10	8000
089087	32 H	33-64	17,5	30	10	16	8000

A14

Driving discs, toothed, **right- and left-hand rotation**, max. workpiece hardness 35 HRC

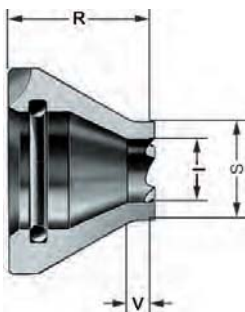

Item no.	Clamping circuit Ø S mm	Approx. turning range	l mm	R mm	V mm	Assoc. centre point Ø Y mm	Axial load max. N
088541	8	9-16	4,5	38	4	4	4000
088542	10	11-20	4,5	38	4	4	6000
088543	12	13-24	7	36	4	6	6000
088544	16	17-32	11	33	4	10	6000
314995	20	21-40	13	30	4	12	8000
089578	25	26-50	17	30	4	16	10000

Driving discs with carbide tothing on request

Accessories CoA

Accessories face drivers CoA

A14
Driving discs, toothed, right-hand rotation, max. workpiece hardness 35 HRC

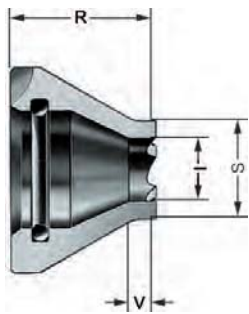

Item no.	Clamping circuit Ø S mm	Approx. turning range	l mm	R mm	V mm	Assoc. centre point Ø Y mm	Axial load max. N
088061	8	9-16	4,5	38	4	4	4000
088062	10	11-20	4,5	38	4	4	6000
088063	12	13-24	7	36	4	6	6000
088064	16	17-32	11	33	4	10	6000
088065	20	21-40	13	30	4	12	8000
088066	25	26-50	17	30	8	16	10000
088067	32	33-64	22	30	10	16	12500

Driving discs with carbide tothing, friction lining or diamond grain on request

A14
Driving discs, toothed, left-hand rotation, max. workpiece hardness 35 HRC

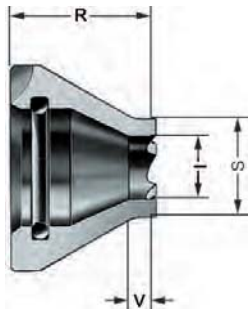

Item no.	Clamping circuit Ø S mm	Approx. turning range	l mm	R mm	V mm	Assoc. centre point Ø Y mm	Axial load max. N
088081	8	9-16	4,5	38	4	4	4000
088082	10	11-20	4,5	38	4	4	6000
088083	12	13-24	7	36	4	6	6000
088084	16	17-32	11	33	4	10	6000
088085	20	21-40	13	30	4	12	8000
088086	25	26-50	17	30	8	16	10000
088087	32	33-64	22	30	10	16	12500

Driving discs with carbide tothing, friction lining or diamond grain on request

A14
Driving discs, with interchangeable carbide driving plates 9.5 x 3.2, right- and left-hand rotation, max. workpiece hardness 40 HRC

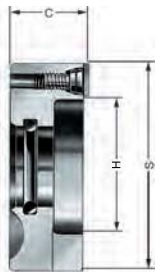

Item no.	Clamping circuit Ø S mm	Approx. turning range	H mm	C mm	Assoc. centre point Ø Y mm	Axial load max. N
088548	40	41-80	20	24	16	14000
088549	50	51-100	28	24	16	14000
088550	63	64-126	41	24	16	14000
088551	80	81-160	58	24	16	14000

A14
Driving discs, with interchangeable carbide driving plates 9.5 x 3.2, right-hand rotation, max. workpiece hardness 40 HRC

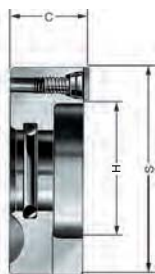

Item no.	Clamping circuit Ø S mm	Approx. turning range	H mm	C mm	Assoc. centre point Ø Y mm	Axial load max. N
088068	40	41-80	20	24	16	14000
088069	50	51-100	28	24	16	14000
088070	63	64-126	41	24	16	14000
088071	80	81-160	58	24	16	14000

Accessories CoA

A14

Driving discs, with interchangeable carbide driving plates 9.5 x 3.2, **left-hand rotation**

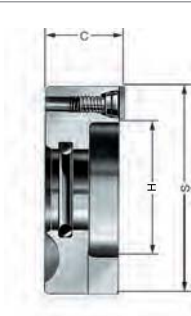

Item no.	Clamping circuit Ø S mm	Approx. turning range	H mm	C mm	Assoc. centre point Ø Y mm	Axial load max. N
088088	40	41-80	20	24	16	14000
088089	50	51-100	28	24	16	14000
088090	63	64-126	41	24	16	14000
088091	80	81-160	58	24	16	14000

Accessories face drivers CoA

A14

Centres CoA

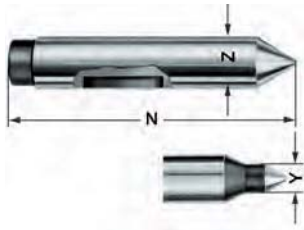

Item no.	Clamping circuit Ø S mm	N mm	Y mm	Z mm
088351	8-10	90	4	16
088352	12	90	6	16
088353	16	90	10	16
088354	20	90	12	16
088355	25-80	90	16	16
086758	25-80	110	16	16

A14

Centres CoA

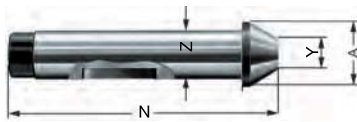

Item no.	Taper Ø		N mm	Z mm	Weight approx. g
	A mm	Y mm			
086619	21	10	90	16	136
086620	27	16	90	16	153
688878	34	23	90	16	190
086621	40	29	90	16	210
688880	48	37	90	16	250
086622	56	45	90	16	312

A14

Carbide driving plates, right- and left-hand rotation



Item no.	Size	Clamping circuit Ø mm
088970	6x3,2	20-32
087931	9,5x3,2	40-80

A14

Carbide driving plates, right- or left-hand rotation



Item no.	Size	Clamping circuit Ø mm
088810	6x3,2	20-32
088209	9,5x3,2	40-80

A14

Mounting sleeve for clamping the face driver in the lathe chuck

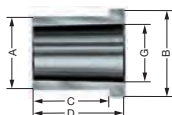

Item no.	MT inside	A mm	B mm	C mm	D mm	G mm
085033	3	32	39	32	40	23,825
085034	4	40	47	42	50	31,267
085035	5	55	62	52	60	44,399
085036	6	75	83	62	70	63,448

Accessories CoA

Accessories face drivers CoA

C15
Threaded pin

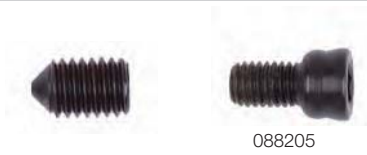

Item no.	Size	Clamping circuit Ø mm
234695	M 4 x 6	20
048205	M 5 x 8	25+32
088205	M 5 x 8	40-80

C15
O-ring



Item no.	Size
006252	21,82x3,53

A14
RÖHM slide rule for determining the axial tailstock force



Item no.
088230

C15
Semifluid grease F25 for face driver



Item no.	Design	Contents
036397	tin	1000 g

CoA - product ranges

A14

Basic equipment in a carton, hydraulic pressure compensation, clamping dia. 12 + 32 mm, turning range 13-64 mm



Item no.	MT	right-hand rotation	left-hand rotation	With draw-off nut.	Weight approx. g
088553	3	•			2100
088557	3	•		•	2400
088573	3		•		2100
088577	3		•	•	2400
088554	4	•			2400
088558	4	•		•	2700
088574	4		•		2400
088578	4		•	•	2700
088555	5	•			3300
088559	5	•		•	3600
088575	5		•		3300
088579	5		•	•	3600
088556	6	•			4900
088560	6	•		•	5200
088576	6		•		4900
088580	6		•	•	5200

A14

Small assortment in wooden box, hydraulic pressure compensation, clamping dia. 12-50 mm, turning range 13-100 mm

Included in delivery: 1x basic body, 4x driving discs (clamping circuit Ø 12, 20, 32, 50), 2x centre points (centering Ø 6, 12)



Item no.	MT	right-hand rotation	left-hand rotation	With draw-off nut.	Weight approx. g
088501	3	•			3900
088511	3	•		•	4200
088521	3		•		3900
088531	3		•	•	4200
088502	4	•			4300
088512	4	•		•	4600
088522	4		•		4300
088532	4		•	•	4600
088503	5	•			4900
088513	5	•		•	5200
088523	5		•		4900
088533	5		•	•	5200
088504	6	•			6600
088514	6	•		•	6800
088524	6		•		6600
088534	6		•	•	6800

A14

Large assortment in wooden box, hydraulic pressure compensation, clamping dia. 10-80 mm, turning range 11-160 mm

Included in delivery: 1x basic body, 10x driving discs (clamping circuit Ø 10, 12, 16, 20, 25, 32, 40, 50, 63, 80), 5x centre points (centering Ø 4, 6, 10, 12, 16)



Item no.	MT	right-hand rotation	left-hand rotation	With draw-off nut.	Weight approx. g
088218	3	•			5600
088223	3		•		5600
088233	3	•		•	5900
088238	3		•	•	5900
088219	4	•			6000
088224	4		•		6000
088234	4	•		•	6300
088239	4		•	•	6300
088220	5	•			6600
088225	5		•		6600
088235	5	•		•	6900
088240	5		•	•	6900
088221	6	•			8300
088226	6		•		8300
088236	6	•		•	8500
088241	6		•	•	8500

CoK - power-operated 8-80 mm

Power-operated face drivers CoK

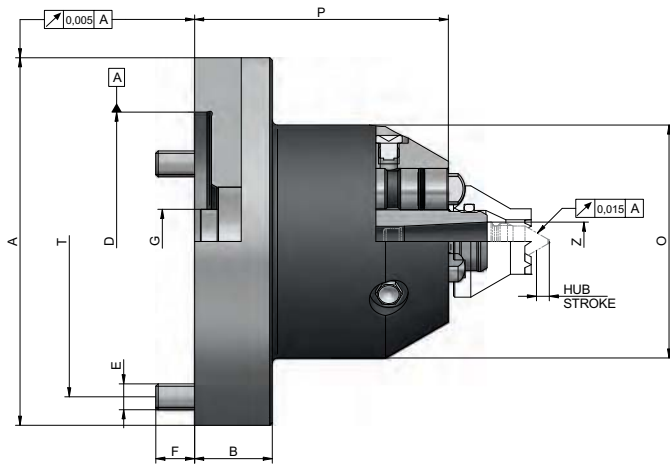

APPLICATION

For machining workpieces with high unbalance, heavy weight, high chip removal or irregular cutting.

TYPE

Force-actuated face driver with mechanical pressure compensation.
Clamping circuit Ø 8-80 mm.
Max. workpiece weight 350 kg.

CUSTOMER BENEFITS

- ⊕ Maximum concentricity deviation of 0.015 mm for maximum precision
- ⊕ Workpiece longitudinal stop realized in centering
- ⊕ Low centering force, even at max. cutting load
- ⊕ Maximum flexibility thanks to universal exchange of driving disc and centre point

TECHNICAL FEATURES

- The drivers are pressed against the workpiece with force-actuation



C15
Basic body (without centre, without draw-off nut), mechanical

Item no.	A mm	B mm	D mm	E	F mm	G mm	O mm	P mm	T mm	Z mm	Centres stroke mm	Weight approx. g
313900	142	30	100	M 10	15	25	90	98	120	15	5	6500

Draw-off nut M 14x1.5 Id.No. 089229

Adapter plate CoK

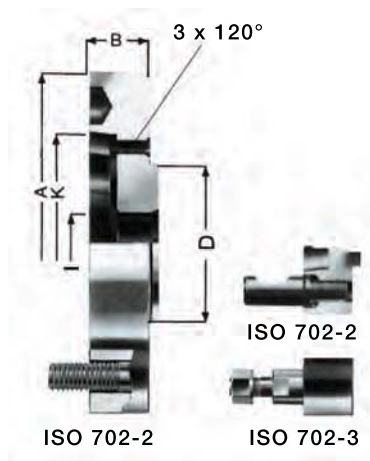

A14
Adapter plate short taper

Item no.	Design	Taper	A mm	B mm	D mm	I mm	K mm	Weight approx. g
088485	ISO 702-1	5	140	30	100	38	82,563	3100
088486	ISO 702-1	6	167	35	100	38	106,39	4800
088487	ISO 702-1	8	216	40	100	38	139,735	8700
088488	ISO 702-1	11	280	45	100	38	196,885	17000
088480	ISO 702-3	5	140	30	100	38	82,563	3100
088481	ISO 702-3	6	167	35	100	38	106,39	4800
088482	ISO 702-3	8	216	40	100	38	139,735	8700
088483	ISO 702-3	11	280	45	100	38	196,885	17000
088495	ISO 702-2	5	140	30	100	38	82,563	3100
088496	ISO 702-2	6	167	35	100	38	106,39	4800
088497	ISO 702-2	8	216	40	100	38	139,735	8700
088498	ISO 702-2	11	280	45	100	38	196,885	17000

Accessories CoK

A14

Driving discs, toothed, right-hand rotation, max. workpiece hardness 35 HRC

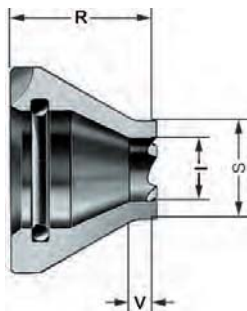

Item no.	Clamping circuit Ø S mm	Approx. turning range	l mm	R mm	V mm	Assoc. centre point Ø Y mm	Axial load max. N
088061	8	9-16	4,5	38	4	4	4000
088062	10	11-20	4,5	38	4	4	6000
088063	12	13-24	7	36	4	6	6000
088064	16	17-32	11	33	4	10	6000
088065	20	21-40	13	30	4	12	8000
088066	25	26-50	17	30	8	16	10000
088067	32	33-64	22	30	10	16	12500

Driving discs with carbide tothing, friction lining or diamond grain on request

A14

Driving discs, toothed, left-hand rotation, max. workpiece hardness 35 HRC

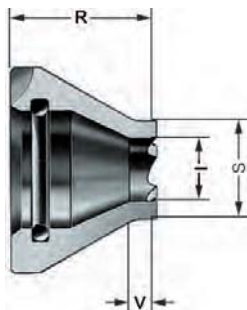

Item no.	Clamping circuit Ø S mm	Approx. turning range	l mm	R mm	V mm	Assoc. centre point Ø Y mm	Axial load max. N
088081	8	9-16	4,5	38	4	4	4000
088082	10	11-20	4,5	38	4	4	6000
088083	12	13-24	7	36	4	6	6000
088084	16	17-32	11	33	4	10	6000
088085	20	21-40	13	30	4	12	8000
088086	25	26-50	17	30	8	16	10000
088087	32	33-64	22	30	10	16	12500

Driving discs with carbide tothing, friction lining or diamond grain on request

A14

Driving discs, with interchangeable carbide driving plates 9.5 x 3.2, right-hand rotation, max. workpiece hardness 40 HRC

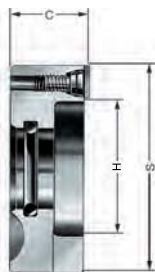

Item no.	Clamping circuit Ø S mm	Approx. turning range	H mm	C mm	Assoc. centre point Ø Y mm	Axial load max. N
088068	40	41-80	20	24	16	14000
088069	50	51-100	28	24	16	14000
088070	63	64-126	41	24	16	14000
088071	80	81-160	58	24	16	14000

A14

Driving discs, with interchangeable carbide driving plates 9.5 x 3.2, left-hand rotation, max. workpiece hardness 40 HRC

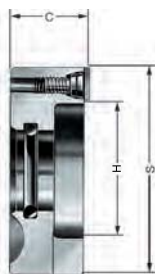

Item no.	Clamping circuit Ø S mm	Approx. turning range	H mm	C mm	Assoc. centre point Ø Y mm	Axial load max. N
088088	40	41-80	20	24	16	14000
088089	50	51-100	28	24	16	14000
088090	63	64-126	41	24	16	14000
088091	80	81-160	58	24	16	14000

Accessories CoK

Power-operated face drivers CoK

C15
Centres, CoK

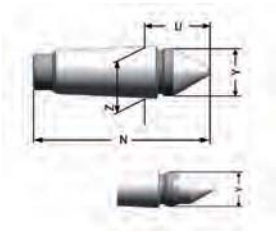

Item no.	Clamping circuit Ø S mm	N mm	U mm	Y mm	Z mm	Workpiece weight max. kg
088121	8-10	67,5	28	4	15	55
088122	12	67	28	6	15	75
088123	16	67	28	10	15	150
088124	20-32	64	25	12	15	250
085002	40-80	60	21	M 14x1,5	15	350

A14
Carbide driving plates, right- or left-hand rotation



Item no.	Size	Clamping circuit Ø mm
088209	9,5x3,2	40-80

A14
Carbide driving plates, right- and left-hand rotation



Item no.	Size	Clamping circuit Ø mm
087931	9,5x3,2	40-80

C15
Clamping spindle



Item no.	Size	Clamping circuit Ø mm
088205	M 5 x 8	40-80

C15
O-ring



Item no.	Size
006252	21,82x3,53